



KC-6207

B. E. - II (Sem. III) (Electrical) Examination
November / December – 2012
Computer Application for Electrical Engineering
(Old Syllabus)

Time : 3 Hours]

[Total Marks : 100

Instructions :

(1)

नीचे दर्शावेल निशानीवाणी विगतो उत्तरवही पर अवश्य लभवी.
Fillup strictly the details of signs on your answer book.

Name of the Examination :
B. E. - 2 (SEM. 3) (ELECTRICAL)

Name of the Subject :
COMPUTER APPLICATION FOR ELECTRICAL ENGINEERING (OLD)

Subject Code No. : **6 2 0 7** Section No. (1, 2,.....): **NIL**

Seat No. :

Student's Signature

- (2) Attempt all questions.
- (3) Figures to the extreme right side indicate full marks.
- (4) Assume appropriate data if requires.
- (5) Support your answers with neat and clean diagrams and wavefrms.
- (6) Students may use Casio MS-100, 100-W or equivalent scientific calculators.

1 (a) Do as directed : 10

- (1) Let $x = 0.06787$, compute relative error if the number is rounded - off to three decimal digits.
- (2) For $f(x) = x^3 - 2x - 5$, find the root interval.
- (3) Write general formula for Newton - Raphson method.
- (4) If $f(x_3) < 0$, and $x_3 = \frac{x_1 + x_2}{2}$ then what will be the new root interval for bi-section method.
- (5) Specify types of the following equation :
 - (i) $x^4 - 8x^3 - 39x^2 - 62x + 5 = 0$
 - (ii) $x \cdot e^x - x \cdot \sin x = 0$

(b) (1) Taylor's series for $\log_e(1-x)$ is 6

$$\log_e(1-x) = -x + \frac{x^2}{2} - \frac{x^3}{3} + \frac{x^4}{4} - \dots + (-1)^n \cdot \frac{x^n}{n}$$

find n such that series determines the value of $\log_e^{0.8}$ correct up to nine decimal places.

(2) Explain Round - off error with example. 4

2 (a) Find root of equation, lying in an interval $[1, 2]$, correct up to four decimal places using Bi-section method. 10

$$x^4 - 2x^3 + 3x^2 - 4x + 1 = 0$$

OR

(a) Find root of equation, lying in an interval $[0, 1]$ correct up to four decimal places using secant method 10

$$e^x \tan x - 1 = 0$$

(b) Develop an algorithm for Newton - Raphson method. 5

3 (a) Write equations for V_1 , V_2 and V_3 using nodal voltage Analysis for the network shown in fig. 1. Find the values of V_1 , V_2 and V_3 using Gauss-elimination method. 10

Fig. 1

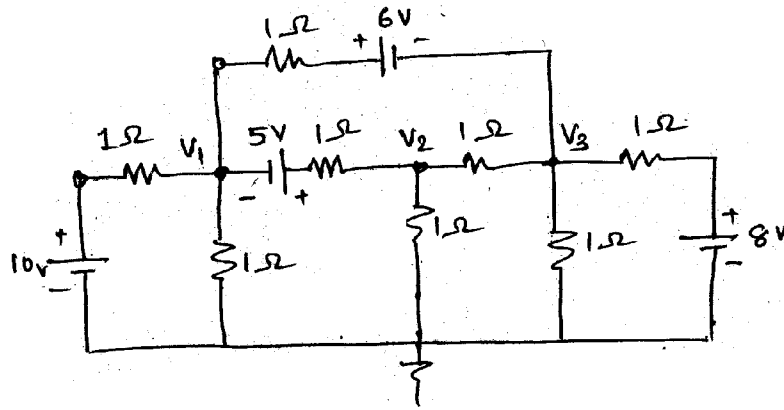

OR

3 (a) Write equations for V_1 , V_2 and V_3 using nodal voltage analysis for the network shown in fig. 1. Find values of V_1 , V_2 and V_3 using Gauss Jordan Method. 10

(b) Solve the following system of linear equations using Jacobi's iterative method upto four iteration. 5

$$2x_1 + 8x_2 + 2x_3 = 14$$

$$x_1 + 6x_2 - x_3 = 13$$

$$2x_1 - x_2 + 2x_3 = 5$$

- 4 (a) Attempt all questions : 10
- (1) Explain the term Interpolation. 2
 - (2) Mention the minimum requirement of intervals to solve numerical integration using following methods : 2
 - (i) Trapezoidal methods
 - (ii) Simpson's 1/3 rule.
 - (3) Construct a Newton's forward difference table for the four set of data. 2
 - (4) What is the importance of initial values to solve any ordinary differential equation ? 2
 - (b) (1) Enlist the difference between Simpson's 1/3 rule and Simpson's 3/8 rule to solve numerical integration. 2
 - (b) (2) Obtain the average value of current with a given waveform. Use Simpson's 1/3 rule of integration for this. Total number of intervals is equal to four. 5

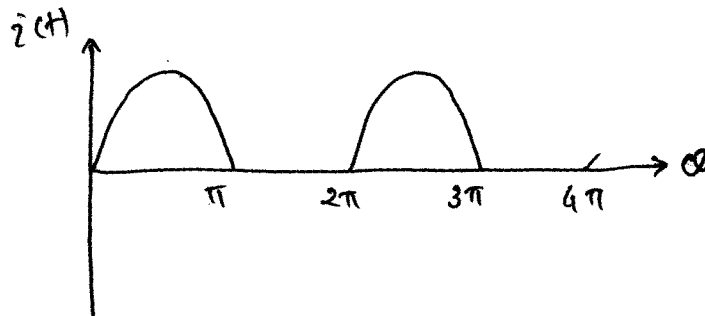

Fig. 2

- (2) Write an algorithm for Runge-Kutta second order method for solving an ordinary differential equation. 5
- 5 (a) The following test results were obtained from a test on 400 D.C. series motor : 8
- | | | | | | |
|---------------|-------|-------|-------|-----|-----|
| Current (Amp) | 20 | 30 | 40 | 50 | 60 |
| Torque (N-M) | 128.6 | 230.3 | 349.5 | 469 | 570 |
- Find torque when current is 25 Amp. Use Newton's Divided difference interpolation formula.
- (b) Write a "C" programme to solve numerical integration using Simpson's 3/8 rule. Mention the meaning of each variable used. Write a programme for tabulated data. 7

OR

- 5 (a) In an electrical network the resistor and inductor are connected in series as shown in following diagram. The initial condition at time $t = 0$ current, $i = 0$. Find out the current in the circuit when the time elapsed is 1 time constant. Use Euler's method. Step size is 0.1

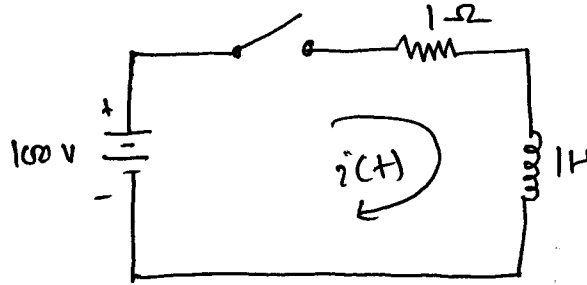

Fig. 3

- (b) Write a "C" programme of Newton's forward difference interpolation technique. Mention the meaning of each variable used.

6 Write any three questions :

- (1) Write an algorithm of Trapezoidal rule to solve numerical intergration.
- (2) Using modifies Euler's method, obtain the solution of the differential equation, $dy/dt = t + \sqrt{y}$ with the initial condition $y_0 = 1$ at $t_0 = 0$ for the range $0 \leq t \leq 0.6$ in the steps of 0.2.
- (3) The sales in particular department store for the last five years is given in the following table :

Year	1974	1976	1978	1980	1982
Sales (in Lakhs)	40	43	48	52	57

Estimate the sales of the year 1979 using proper Newton's Interpolation Method.

- (4) Write a "C" programme to solve ordinary differential equation using Raunge-Kutta fourth order method.